

Product datasheet

L 38 W/830

LUMILUX T8 | Tubular fluorescent lamps 26 mm, with G13 bases



Product datasheet

Technical data

Electrical data

| | |
|-----------------|----------|
| Nominal current | 0.43 A A |
|-----------------|----------|

Photometrical data

| | |
|---------------------------|--------------------|
| Light color (designation) | LUMILUX Warm White |
| Rated LLMF at 2,000 h | 0.96 |
| Rated LLMF at 4,000 h | 0.94 |
| Rated LLMF at 6,000 h | 0.93 |
| Rated LLMF at 8,000 h | 0.91 |
| Rated LLMF at 12,000 h | 0.91 |
| Rated LLMF at 16,000 h | 0.9 |
| Rated LLMF at 20,000 h | 0.89 |
| Luminous flux | 3300 lm |

Dimensions & weight



| | |
|---|------------|
| Tube diameter | 26 mm |
| Length with base excl. base pins/connection | 1047 mm |
| Product weight | 130.00 g |
| Overall length | 1061.20 mm |

Lifespan

| | |
|--------------|---------|
| Service life | 16000 h |
|--------------|---------|

Additional product data

| | |
|-----------------------------------|--------|
| Mercury content | 3.0 mg |
| Appropriate disposal acc. to WEEE | Yes |

Product datasheet

Certificates & standards

| | |
|-------------------------|-----------------|
| Energy efficiency class | G |
| Energy consumption | 40.00 kWh/1000h |

Environmental information

| Information according Art. 33 of EU Regulation (EC) 1907/2006 (REACH) | |
|---|---------------|
| Date of Declaration | 19-01-2022 |
| Primary Article Identifier | 4050300518152 |
| Declaration No. in SCIP database | In work |

Light Distribution

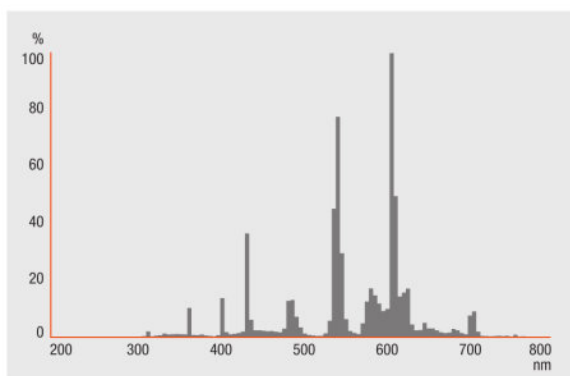

FL_830

System guarantee

OSRAM System+ Guarantee in combination with OSRAM ECGs

Product datasheet

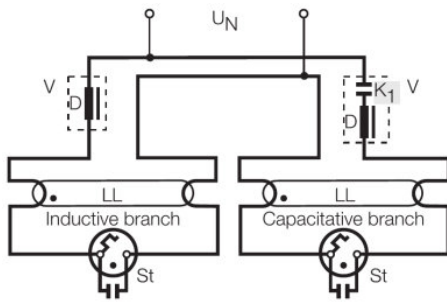

DUO CIRCUIT

Ecodesign regulation information:

Separate control gear and light sources must be disposed of at certified disposal companies in accordance with Directive 2012/19/EU (WEEE) in the EU and with Waste Electrical and Electronic Equipment (WEEE) Regulations 2013 in the UK. For this purpose, collection points for recycling centres and take-back systems (CRSO) are available from retailers or private disposal companies, which accept separate control gear and light sources free of charge. In this way, raw materials are conserved and materials are recycled.

References / Links

For more information on the system guarantee and the terms and conditions of the guarantee visit

- ▶ www.osram.com/system-guarantee

For more information on QUICKTRONIC electronic control gear go to

- ▶ www.osram.com/QUICKTRONIC

Disclaimer

Subject to change without notice. Errors and omission excepted. Always make sure to use the most recent release.

OSRAM is distribution partner
of LEDVANCE of LAMPS

OSRAM

OSRAM GmbH
Marcel-Breuer-Strasse 6
80807 Munich, Germany

L 38 W/830

LUMILUX T8 | Tubular fluorescent lamps 26 mm, with G13 bases

| Product name | Product name ECG | EAN | Nominal current | Nominal wattage + Power loss | Power factor λ [PIM] | Luminous flux at 35 °C |
|--------------|-----------------------|---------------|-----------------|------------------------------|------------------------------|------------------------|
| L 38 W/830 | QTi 1x14/24/21/39 GII | 4008321383334 | 0.09 A | 35.00 W | 0.96 | 3300 lm |
| | QTi DALI 1x36 DIM | 4050300870427 | 0.16 A | 36.00 W | 0.98 | 3300 lm |
| | QTi DALI 2x36 DIM | 4050300870885 | 0.31 A | 69.00 W | 0.98 | 3300 lm |

| Product name | Product name ECG | EAN | Number of lighting outlets |
|--------------|-----------------------|---------------|----------------------------|
| L 38 W/830 | QTi 1x14/24/21/39 GII | 4008321383334 | 1 |
| | QTi DALI 1x36 DIM | 4050300870427 | 1 |
| | QTi DALI 2x36 DIM | 4050300870885 | 2 |