

# Product datasheet

## L 30 W/76

OSRAM NATURA T8 | Tubular fluorescent lamps 26 mm, with G13 bases, for food presentation



- Bakeries, meat processors, butchers Shops Supermarkets and department stores Especially suitable for the food sector (DIN 10504)

- Specially tailored spectral distribution Food looks fresh and appetizing without unduly beautifying it



# Product datasheet

## Technical data

### Electrical data

Nominal current	0.37 A A
-----------------	----------

### Photometrical data

Light color (designation)	NATURA
Rated LLMF at 2,000 h	0.88
Rated LLMF at 4,000 h	0.83
Rated LLMF at 6,000 h	0.8
Rated LLMF at 8,000 h	0.77
Rated LLMF at 12,000 h	0.74
Rated LLMF at 16,000 h	0.72
Luminous flux	1300 lm

### Dimensions & weight



Tube diameter	26 mm
Length with base excl. base pins/connection	895,00 mm
Product weight	132.00 g
Overall length	908.80 mm

### Lifespan

Service life	18000 h
--------------	---------

### Additional product data

Mercury content	5.3 mg
Product remark	Not for general lighting
Appropriate disposal acc. to WEEE	Yes

## Product datasheet

### Certificates & standards

Energy consumption	32.00 kWh/1000h
--------------------	-----------------

### Environmental information

Information according Art. 33 of EU Regulation (EC) 1907/2006 (REACH)	
Date of Declaration	18-04-2022
Primary Article Identifier	4050300010540
Declaration No. in SCIP database	In work

### Light Distribution

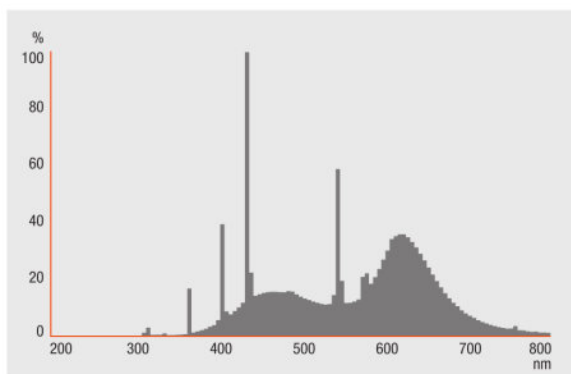

FL\_76\_Natura

## Product datasheet

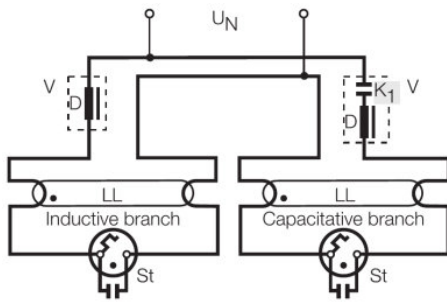

### DUO CIRCUIT

#### Ecodesign regulation information:

Separate control gear and light sources must be disposed of at certified disposal companies in accordance with Directive 2012/19/EU (WEEE) in the EU and with Waste Electrical and Electronic Equipment (WEEE) Regulations 2013 in the UK. For this purpose, collection points for recycling centres and take-back systems (CRSO) are available from retailers or private disposal companies, which accept separate control gear and light sources free of charge. In this way, raw materials are conserved and materials are recycled.

#### Logistical Data

Product code	Product description	Packaging unit (Pieces/Unit)	Dimensions (length x width x height)	Volume	Gross weight
4050300010540	L 30 W/76	Shipping carton box 10 Pieces Sleeves	937 mm x 69 mm x 145 mm	9.37 dm <sup>3</sup>	1661.00 g

The mentioned product code describes the smallest quantity unit which can be ordered. One shipping unit can contain one or more single products. When placing an order, for the quantity please enter single or multiples of a shipping unit.

#### References / Links

For more information on QUICKTRONIC electronic control gear go to

▶ [www.osram.com/QUICKTRONIC](http://www.osram.com/QUICKTRONIC)

#### Disclaimer

Subject to change without notice. Errors and omission excepted. Always make sure to use the most recent release.

OSRAM is distribution partner  
of LEDVANCE of LAMPS

**OSRAM**

OSRAM GmbH  
Marcel-Breuer-Strasse 6  
80807 Munich, Germany